

Technical Specifications	
Model	Haiku™ Bamboo
Model number	S3150-A0
Fan diameter	60 in. (1524 mm)
Motor and assembly finishes	Black
Airfoil material	Bamboo
Airfoil finishes	Caramel or Cocoa
Number of airfoils	3
Motor type	EC motor with a digital inverter drive
Controller included	Yes, remote
Controller features	On/off
	Sleep mode
	Off timer
	Whoosh mode
	Reverse
Mount and drop tube	Standard length, included (10.2 in. / 260 mm)
Hanging weight	13.2 lb (6 kg)
Number of fan speeds	7
Operating voltage	100–240 VAC, 1Φ
Operating frequency	50–60 Hz
RPM (min/max)	66/195 RPM
Amps (min/max)	0.05 - 0.363 A
Watts (min/max)	2/30 W
Ambient operational temperature range	32°–120° F (0–49° C)
Environment	UL listed for dry locations
Fan mode indicator	LED display
Warranty*	Limited lifetime

**Controller**

Shown with wall mount

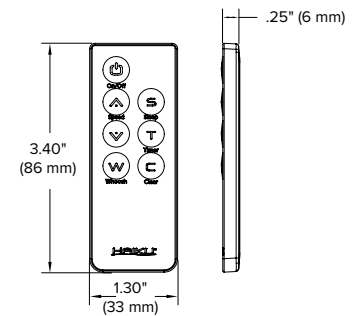

**Color Options**



\* See Haiku warranty in installation guide for complete details

855-MY HAIKU (855-694-2458) | WWW.HAIKUFAN.COM



Ask how Haiku Fans contribute to LEED®-NC 2009 credits in: Optimized Energy Performance; Enhanced Refrigerant Management; Minimum Indoor Air Quality Performance; Increased Ventilation; Thermal Comfort - Design; Innovation in Design and LEED-H 2008 credits in: Advanced Lighting Package; High Efficiency Appliances



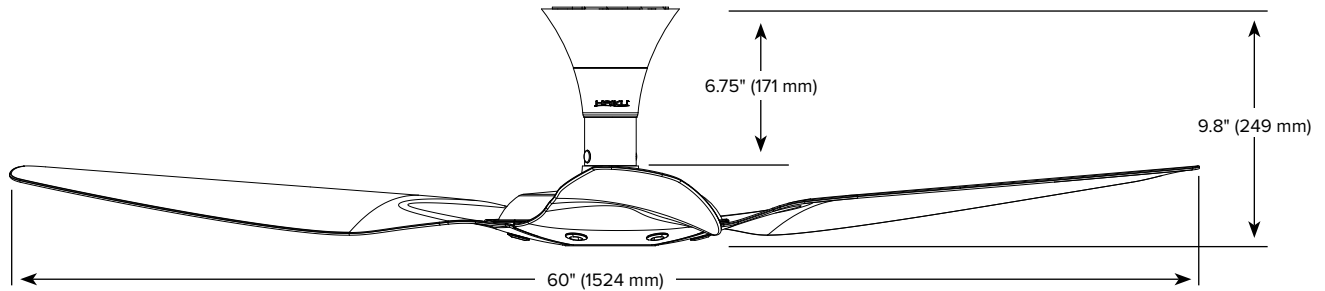

Technical Specifications	
Model	Haiku™ Bamboo
Model number	S3150-S1
Fan diameter	60 in. (1524 mm)
Motor and assembly finishes	Black
Airfoil material	Bamboo
Airfoil finishes	Caramel or Cocoa
Number of airfoils	3
Motor type	EC motor with a digital inverter drive
Controller included	Yes, remote
Controller features	On/off
	Sleep mode
	Off timer
	Whoosh mode
	Reverse
Mount and drop tube	Short length, included (6.3 in. / 160 mm)
Hanging weight	13.2 lb (6 kg)
Number of fan speeds	6
Operating voltage	100–240 VAC, 1Φ
Operating frequency	50–60 Hz
RPM (min/max)	68/170 RPM
Amps (min/max)	0.05 - 0.363 A
Watts (min/max)	2/30 W
Ambient operational temperature range	32°–120° F (0–49° C)
Environment	UL listed for dry locations
Fan mode indicator	LED display
Warranty*	Limited lifetime

### Controller

Shown with wall mount

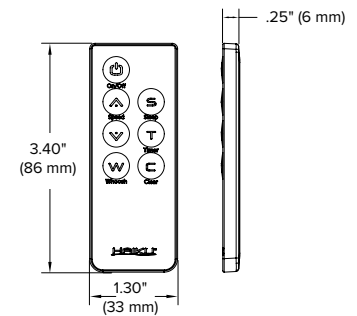

### Color Options



\* See Haiku warranty in installation guide for complete details

855-MY HAIKU (855-694-2458) | WWW.HAIKUFAN.COM



Ask how Haiku Fans contribute to LEED®-NC 2009 credits in: Optimized Energy Performance; Enhanced Refrigerant Management; Minimum Indoor Air Quality Performance; Increased Ventilation; Thermal Comfort - Design; Innovation in Design and LEED-H 2008 credits in: Advanced Lighting Package; High Efficiency Appliances



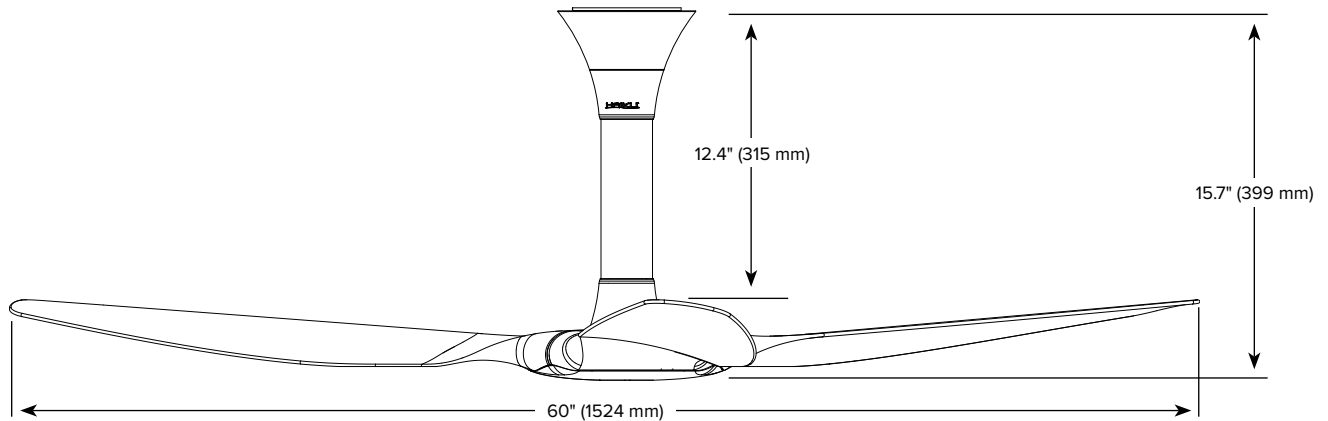

Technical Specifications	
Model	Haiku™
Model number	K3150-A0
Fan diameter	60 in. (1524 mm)
Motor and assembly finishes	Black or white
Airfoil material	Matrix composite
Airfoil finishes	Black or white
Number of airfoils	3
Motor type	EC motor with a digital inverter drive
Controller included	Yes, remote
Controller features	On/off
	Sleep mode
	Off timer
	Whoosh mode
	Reverse
Mount and drop tube	Standard length, included (10.2 in. / 260 mm)
Hanging weight	13.2 lb (6 kg)
Number of fan speeds	7
Operating voltage	100–240 VAC, 1Φ
Operating frequency	50–60 Hz
RPM (min/max)	66/195 RPM
Amps (min/max)	0.05 - 0.363 A
Watts (min/max)	2/30 W
Ambient operational temperature range	32°–120° F (0–49° C)
Environment	UL listed for dry or damp (covered outdoor) locations
Fan mode indicator	LED display
Warranty*	Limited lifetime

**Controller**

Shown with wall mount

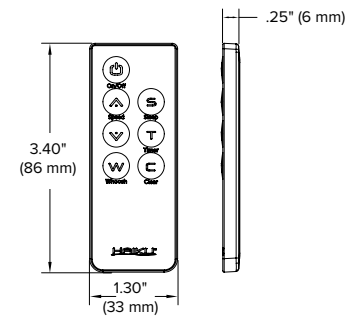

**Color Options**



\* See Haiku warranty in installation guide for complete details

855-MY HAIKU (855-694-2458) | WWW.HAIKUFAN.COM



Ask how Haiku Fans contribute to LEED®-NC 2009 credits in: Optimized Energy Performance; Enhanced Refrigerant Management; Minimum Indoor Air Quality Performance; Increased Ventilation; Thermal Comfort - Design; Innovation in Design and LEED-H 2008 credits in: Advanced Lighting Package; High Efficiency Appliances



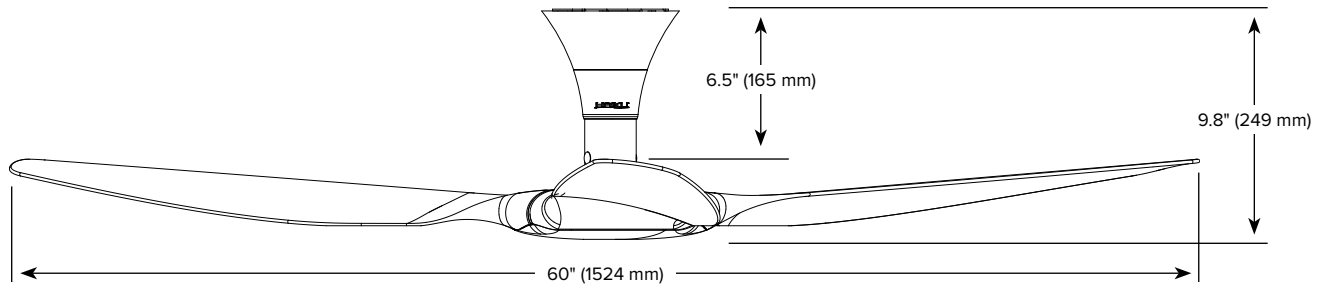

Technical Specifications	
Model	Haiku™
Model number	K3150-S1
Fan diameter	60 in. (1524 mm)
Motor and assembly finishes	Black or white
Airfoil material	Matrix composite
Airfoil finishes	Black or white
Number of airfoils	3
Motor type	EC motor with a digital inverter drive
Controller included	Yes, remote
Controller features	On/off
	Sleep mode
	Off timer
	Whoosh mode
	Reverse
Mount and drop tube	Short length, included (6.3 in. / 160 mm)
Hanging weight	13.2 lb (6 kg)
Number of fan speeds	6
Operating voltage	100–240 VAC, 1Φ
Operating frequency	50–60 Hz
RPM (min/max)	68/170 RPM
Amps (min/max)	0.05 - 0.363 A
Watts (min/max)	2/30 W
Ambient operational temperature range	32°–120° F (0–49° C)
Environment	UL listed for dry or damp (covered outdoor) locations
Fan mode indicator	LED display
Warranty*	Limited lifetime

**Controller**

Shown with wall mount

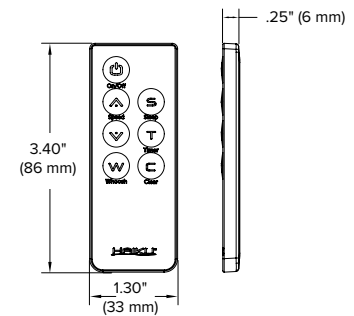

**Color Options**

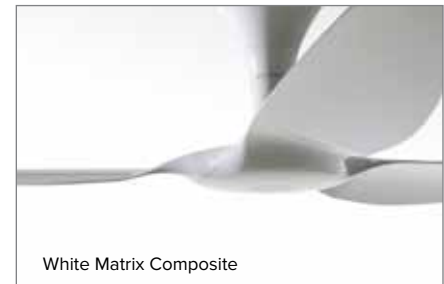

\* See Haiku warranty in installation guide for complete details

855-MY HAIKU (855-694-2458) | WWW.HAIKUFAN.COM



Ask how Haiku Fans contribute to LEED®-NC 2009 credits in: Optimized Energy Performance; Enhanced Refrigerant Management; Minimum Indoor Air Quality Performance; Increased Ventilation; Thermal Comfort - Design; Innovation in Design and LEED-H 2008 credits in: Advanced Lighting Package; High Efficiency Appliances

